

Inlet air temperature	[°C]	0.00	Temperatura parowania	[°C]	-8.00
DT	[K]	8.00	Refrigerant*		R404A
Minimalna ilość chłodziw w komorze		0	Wysokość nad poziomem morza	[m]	0.0
Wymiennik ciepła	Aluminium fin		Obudowa		Standard
Zasilanie wentylatora	Standard		Wentylatory		AC motors
Odtajanie	Absent				

Selected model: 1 x GCE 252E6

Capacity	[kW]	2.81	Margin	[%]	0.0
DT	[K]	8.0	Tot. air flow	[m³/h]	1626.0
Tot. Pres.S.Lev.	[dB(A) @[m]]	40 (5m)			

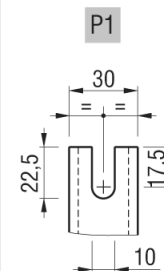
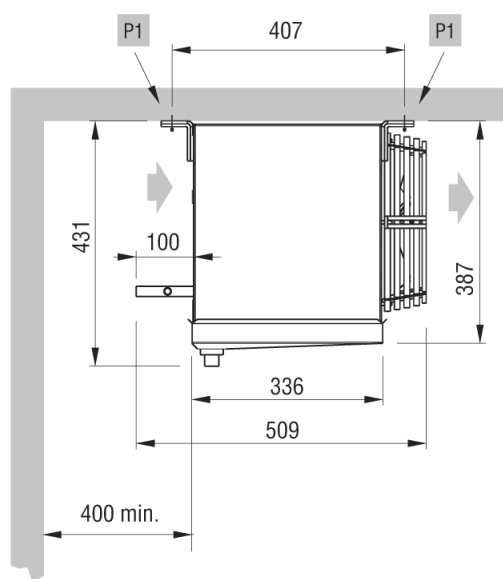
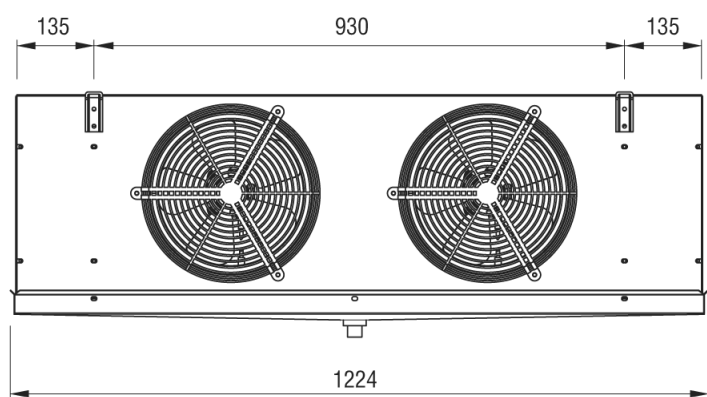

Weight	kg	22.500	PED Category		Cat I
			Design Pressure PS	[bar]	30
Internal surface	m²	1.46	External surface	m²	13.20
Inlet connection		12 mm	Output connection		22 mm
Total circuit capacity	dm³	2.1	Fin spacing	mm	6
Drain connection		1" GAS			
Fan Motors	n.	2	Diameter	mm	250
Air flow	m³/h	1626	Air throw	m	9.0
Feed	V	230/1/50-60	Rotation speed	rpm	1300
Fan Motor	A	1.36	Absorbed power	W	190
Pres.S.Lev. 5 m.	dB(A)	40			



* The safety requirements for the use of refrigerants must comply with the provisions of the EN378 standards and the safety data sheets of each fluid used. The risk assessment for the use of A2L mid-flammable refrigerants shall be conducted by the user based on site requirements

We shall not be liable for the performance and the quality of sold products, if fitted or connected fan motor speed regulation or control systems are different from the ones proposed or installed by us.

Heat exchanger

Aluminium fin EUR 0.00

Casing

Standard EUR 0.00

Fan motor feed

Standard EUR 0.00

Type of fan motor

AC motors EUR 0.00

Defrost

Absent EUR 0.00

Base Price EUR 0.00

Surcharge Water Version EUR 0.00

Total Options EUR 0.00

Total Price EUR 0.00



* The safety requirements for the use of refrigerants must comply with the provisions of the EN378 standards and the safety data sheets of each fluid used. The risk assessment for the use of A2L mid-flammable refrigerants shall be conducted by the user based on site requirements

We shall not be liable for the performance and the quality of sold products, if fitted or connected fan motor speed regulation or control systems are different from the ones proposed or installed by us.