

# FLOWATCH® DESIGN

Complete kit, in-duct pump, for the condensate removal of air conditioners up to 10kW / 36000BTU.

Ref: DE05LC9460

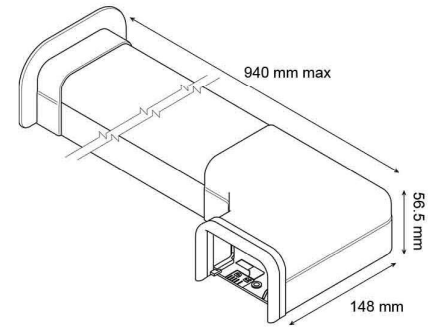
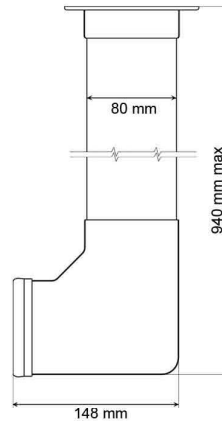

**Hose diameters**  
Suction - 4/6 mm - Supplied  
Discharge - 6/9 mm - Not supplied



## Specifications

Flowrate max	15 l/h
Discharge head max	10 m
Electrical power	19W
Voltage	220-240V 50/60Hz
Alarm	NO-NC 5A
Noise level	20.2 dBA
Protection rating	IP64
Thermal protection	Yes
Operating cycle*	100%
Power / alarm cable lenght	1.6 m
Dimensions	80 x 55 x 800 mm

\* The pump is able to run 100% of the time if necessary.

## Benefits



**mini FLOWATCH® 2 included**  
It assures a high reliability and an easy maintenance.



**20.2 dBA**  
Very silent pump, suitable for an installation in any room.



**IP64 protection rating**  
Protected from water and dust ingress.



**Stop siphoning included**  
Allows to avoid all risk of negative discharge and to secure the pump functioning over time.



**Nice design**  
Thanks to its shape and its finishing accessories (included), FLOWATCH® DESIGN offers great aesthetics qualities.



**Kit pre-assembled**  
Pump is already installed in its duct. Installation is easy and quick.

## Flowrate

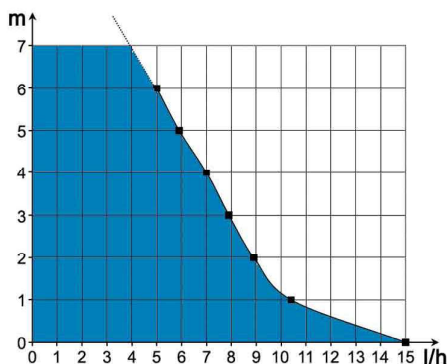

## Pack contents



Duct with elbow- Finishing gasket - Finishing ceiling plate - Pump in absorber bracket - Reservoir with air-vent tube - Power / alarm cable - Reservoir stand - Inlet tube - Suction tube 0.25m - Screws and rawplugs